



# **DINB 13810**

v.1.0

## **DINB 13,8V/1A**

### **DIN rail buffer power supply.**

EN\*

Edition: 2 from 19.01.2015

Supersedes the edition: 1 from 03.11.2014



### PSU features:

- DC 13,8V/1A uninterrupted supply + 0,5A battery charging current
- universal supply voltage range AC 90÷264V
- high efficiency 85%
- battery charging and maintenance control
- deep discharge battery protection (UVP)
- battery output protection against short circuit and reverse polarity connection
- DIN rail mounting
- LED optical indication
- protection type:
  - short-circuit protection SCP
  - surge protection
  - overload protection OLP
- warranty – 2 years from the production date

### TABLE OF CONTENTS:

1. Technical description.
  - 1.1 General description
  - 1.2 Block diagram
  - 1.3 Description of components and power supply connectors
  - 1.4 Technical parameters
2. Installation.
  - 2.1 Requirements
  - 2.2 Installation procedure
3. Power supply operation indication.
  - 3.1 Optical indication
4. Service and operation.
  - 4.1 Overload or short circuit of the power supply output (SCP activation)
  - 4.2 Deep discharge battery protection UVP
  - 4.3 Maintenance

### 1. Technical description.

#### 1.1 General description.

The buffer power supply is designed for uninterrupted supply of devices requiring stabilized voltage of **12V DC (+/-15%)**. The PSU supplies voltage of **13.8V DC** with current efficiency of **I = 1A + 0.5A battery charging**. In the case of mains power failure, the unit will instantly switch to battery power. The PSU is fitted with short circuit protection and overload protection. The power supply unit is in plastic enclosure designed for DIN TH35 rail mounting (35mm width).

**During normal operation, the total current drawn by the device cannot exceed I=1A. The maximum battery charging current is 0.5A. The total current of the receivers + battery is max. 1.5A.**

#### 1.2 Block diagram.

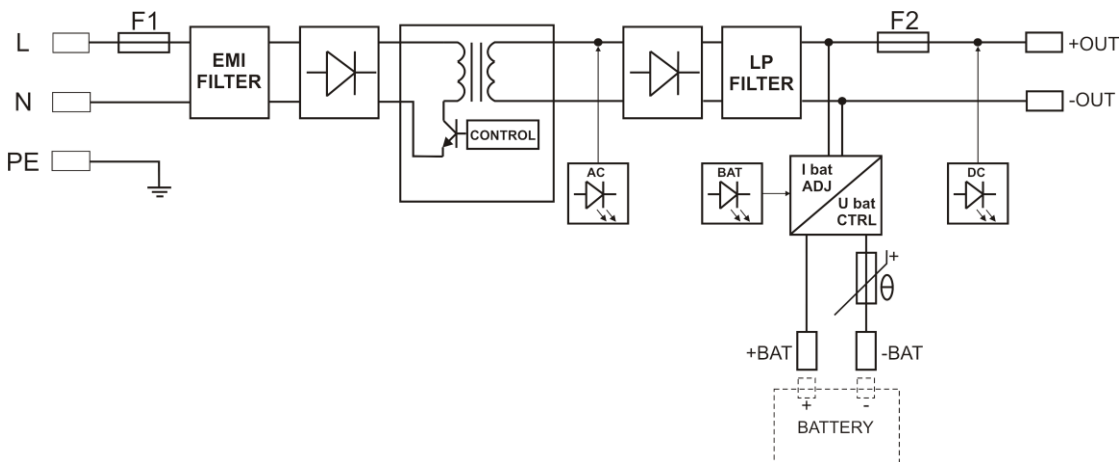



Fig.1. Block diagram of the PSU.

### 1.3 Description of components and power supply connectors (Table 1, Fig.2).

Table 1. The components of power supply.

Component No.	Description
[1]	F1 fuse in the power supply circuit (230V/AC)
[2]	L-N power connector 230V AC,  protective connector PE
[3]	+OUT- DC power output +BAT- battery connector
[4]	F2 fuse in the output circuit +OUT, F 1,5A / 250V
[5]	LED optical indication: AC – AC voltage indication DC – DC voltage indication BAT – battery charging indication

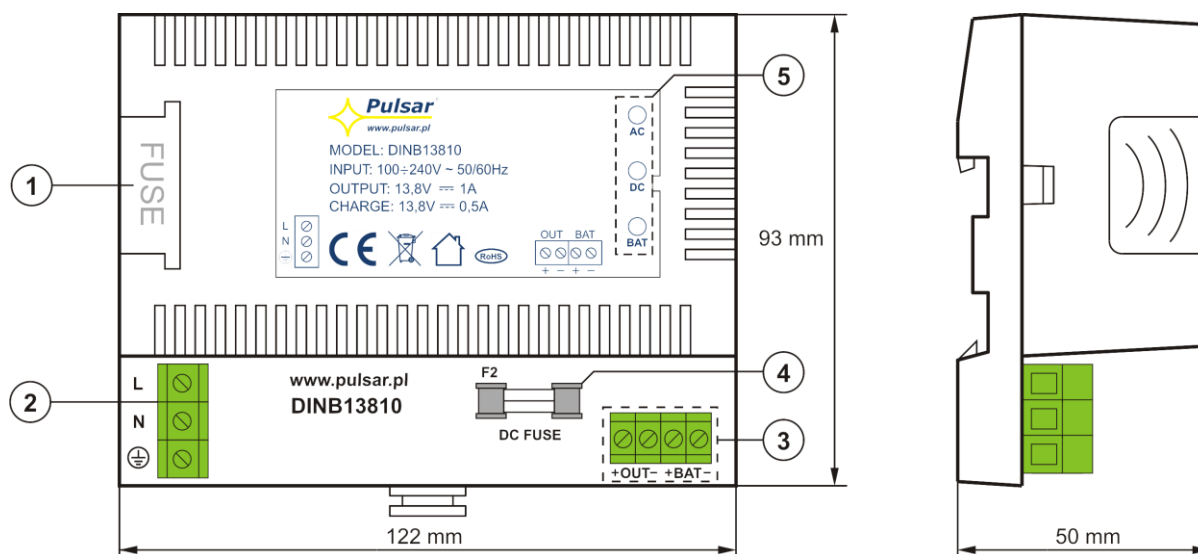

Fig. 2. The view of the PSU module.

#### 1.4 Technical parameters:

- Electrical parameters (Table 2)
- Mechanical parameters (Table 3)
- Safety of use (Table 4)
- Operation parameters (Table 5)

#### Electrical parameters (Table 2)

Mains supply	90±264V AC
Current consumption	0,3A@230VAC max.
PSU power	20W max.
Efficiency	85%
Output voltage	11V± 13,8V DC – buffer operation 9V± 13,8V DC – battery operation
Output current	<b>1A + 0,5A battery charging</b>
Ripple voltage	100mV p-p max.
Battery charging current	0,5A max.
Short-circuit protection SCP	F2 – melting fuse (failure requires fuse replacement)
Overload protection OLP	150-200% of the PSU power, automatic return
Surge protection	varistor
Deep discharge battery protection UVP	U<9V (+/- 0,5V) – disconnection of the battery terminal
Optical indication of operation	YES – LEDs
F1 fuse	T 1,6A / 250V
F2 fuse	F 1,5A / 250V

**Mechanical parameters (Table 3)**

Enclosure dimensions	122 x 93 x 50 (WxHxD) [mm] (+/- 2)
Mounting	TH35 DIN rail
Net/gross weight	0,27 kg/ 0,35 kg
Enclosure	ABS, RAL9003, white
Connectors	Φ0,51-2,05 (AWG 24-12)

**Safety of use (Table 4)**

Protection class PN-EN 60950-1:2007	I (first)
Protection grade PN-EN 60529: 2002 (U)	IP20
Insulation electrical strength: - between input (network) circuit and the output circuits of the PSU (I/P-O/P) - between input circuit and PE protection circuit (I/P-FG) - between output circuit and PE protection circuit (O/P-FG)	3000 V/AC min. 1500 V/AC min. 500 V/AC min.
Insulation resistance: - between input circuit and output circuit	100 MΩ, 500V/DC

**Operation parameters (Table 5)**

Environmental class	II
Operating temperature	-10°C...+40°C
Storing temperature	-25°C...+60°C
Relative humidity	20%...90%, no condensation
Sinusoidal vibrations during operation	unacceptable
Surges during operation	unacceptable
Direct insolation	unacceptable
Vibrations and surges during transport	compliant with the PN-83/T-42106

**2. Installation.****2.1 Requirements.**

The power supply unit should be mounted by a qualified installer, holding relevant permits and licenses (applicable and required for a given country) for 230V/AC and low-voltage installations. The unit should be mounted in confined spaces, in accordance with the 2nd environmental class, with normal relative humidity (RH=90% maximum, no condensation) and temperature range from -10°C up to +40°C. The power supply should operate in a vertical position in order to provide free and convective air flow through ventilating holes of the enclosure

**The power supply load balance should be done before installation. During normal operation, the total current of the receivers should not exceed I=1A. The maximum battery charging current is 0.5A. The total current of the receivers + battery is max. 1.5A.**

The power supply is designed for a continuous operation and is not equipped with a power-switch. Therefore, an appropriate overload protection in the power supply circuit should be provided. Moreover, the user should be informed how to disconnect the power supply unit from the mains supply (usually by assigning an appropriate fuse in the fuse box). The electrical system shall be made in accordance with applicable standards and The unit should be mounted in a metallic enclosure (telecommunication cabinet) fitted with TH35 DIN rail (35 mm width); in order to meet the LVD and EMC requirements, the rules concerning power supply, building-in and shielding should be followed accordingly.

## 2.2 Installation procedure.

1. **Before installation, make sure that the voltage in the 230V power-supply circuit is cut off.**
2. Mount the power supply module on a DIN rail.
3. Connect the power cables to the L-N terminals of the PSU. Connect the ground wire to the terminal marked with the PE symbol. Use a three-core cable (with a yellow and green  protection wire) to make the connection.



**The shock protection circuit shall be done with a particular care: the yellow and green wire coat of the power cable should be connected to the terminal marked with the  symbol. Operation of the PSU without the properly made and fully operational shock protection circuit is UNACCEPTABLE! It can cause damage to the equipment or an electric shock**

4. Connect the receiver cables to the + OUT connector - terminal block on the PSU module.
5. Switch on the 230V AC supply.
6. Connect the battery in accordance with the markings: +BAT red to 'plus', -BAT black to 'minus'.
7. Check the optical indication of the PSU operation: AC, DC, BAT LEDs should be ON.
8. Close the enclosure, cabinet, etc. after installing and checking the operation of the power supply.

## 3. Power supply operation indication.

### 3.1 Optical indication.

The PSU is fitted with three LEDs indicating power supply status: AC, DC and BAT.

- AC – green LED: During normal operation (AC power), the LED is permanently illuminated. No AC power is indicated by turning off the AC LED.
- DC – green LED: indicates DC power at the output of the power supply. During normal operation, the LED is permanently illuminated. In the case of short-circuit or output overload, the LED is off.
- BAT – green LED: indicates battery charging process. During normal operation, the LED is permanently illuminated. If the battery is not charging, the LED is off.

## 4. Service and operation.

### 4.1 Overload or short circuit of the power supply output (SCP activation).

In the case of output overload, the output voltage is automatically disconnected. The voltage is automatically restored once overload is removed.

In the case of short circuit of the OUT output, the F2 fuse in the output circuit becomes permanently damaged; fuse failure is indicated by switching off the DC LED. Restoration of the voltage at the output requires fuse replacement.

The power supply BAT output is protected by the PTC polymer fuse. In the case of short circuit of the BAT output or reverse battery connection, the PTC polymer fuse in the battery circuit becomes activated.

### 4.2 Deep discharge battery protection UVP.

The PSU is fitted with discharged battery disconnection system. If the voltage at the battery terminals drops below  $9V \pm 0.5V$  during battery operation, the battery will be disconnected.

### 4.3 Maintenance.

All maintenance procedures can be performed after disconnecting the power supply from the power network. The PSU does not require any specific maintenance; however, its interior should be cleaned with compressed air if used in dusty conditions.

**WEEE MARK**

**According to the EU WEE Directive – It is required not to dispose of electric or electronic waste as unsorted municipal waste and to collect such WEEE separately.**

The power supply unit is adapted for a sealed lead-acid battery (SLA). After the operation period it must not be disposed of but recycled according to the applicable law.

**THE GENERAL WARRANTY CONDITIONS**

1. Pulsar (the manufacturer) grants a two-years warranty for the equipment, counted from the device's production date.
2. The warranty includes free-of-charge repair or replacement with an appropriate equivalent (the selection is at the manufacturer's discretion) if the malfunction is due to the manufacturer, includes manufacturing or material defects, unless such defects have been reported within the warranty period (item 1).
3. The equipment subject to warranty is to be brought to the place where it was purchased, or directly to the main office of the manufacturer.
4. The warranty applies to complete equipment, accompanied by a properly filled warranty claim with a description of the defect.
5. Should the claim be accepted, the manufacturer is obliged to provide warranty repairs, at the earliest convenience, however not later than within 14 days from the delivery to the service centre of the manufacturer.
6. The repair period mentioned in item 5 may be prolonged, if there are no technical possibilities to carry out the repairs, or if the equipment has been conditionally accepted, due to the breaking warranty terms by the claimant.
7. All the services rendered by force of the warranty are carried out at the service centre of the manufacturer, exclusively.
8. The warranty does not cover the defects of the equipment, resulting from:
  - reasons beyond the manufacturer's control,
  - mechanical damage,
  - improper storage and transport,
  - use that violates the operation manual or equipment's intended use
  - fortuitous events, including lightning discharges, power failures, fire, flood, high temperatures and chemical agents,
  - improper installation and configuration (in defiance with the manual),
9. The warranty is void in any of the following circumstances:
  - construction changes
  - repairs carried out by any unauthorized service center
  - damage or removal of warranty labels
  - modifications of the serial number
10. The liability of the manufacturer towards the buyer is limited to the value of the equipment, determined according to the wholesale prices suggested by the manufacturer on the day of purchase.
11. The manufacturer takes no responsibility for the defects that result from:
  - the damaging, malfunctioning or inability to operate the equipment
  - defects that result from using the equipment outside its stated specifications and operating parameters failing to abide by the recommendations and requirements contained in the manual, or the use of the equipment.

**Pulsar**

Siedlec 150, 32-744 Łapczyca, Poland  
Tel. (+48) 14-610-19-40, Fax. (+48) 14-610-19-50  
e-mail: [biuro@pulsar.pl](mailto:biuro@pulsar.pl), [sales@pulsar.pl](mailto:sales@pulsar.pl)  
http:// [www.pulsar.pl](http://www.pulsar.pl), [www.zasilacze.pl](http://www.zasilacze.pl)