



PS-401230
PS 12V/3A enclosed switch mode power supply



Edition: 10 from 01.03.2018
 Supersedes edition: 9 from 27.05.2014

EN

Features of the power supply unit:

- power output 3A/12÷15V DC*
- universal AC input voltage range 85÷264V
- high efficiency 75%
- LED optical signalisation
- protections:
 - SCP short-circuit protection
 - overvoltage OVP
 - overvoltage protection
 - overload (OLP)
- warranty – 2 year from the production date

1. Technical description.

1.1. General description.

The power supply unit is intended for the feeding of alarm system equipments, which require 12V DC supply voltage and current load **I=3A**. The design enables simple changing of the output voltage, within the range of 12V÷15V DC, using a potentiometer. The power supply unit is protected against short-circuit, overload and overvoltage.

1.2. Technical parameters.

Supply voltage	85 ÷ 264V AC, 120 ÷ 370V DC
Current consumption	0,4A@230V AC max.
Supply power	40W max.
Efficiency	75%
Output voltage	12V DC
Output current $t_{AMB}<30^{\circ}C$	3A - see graph 1.
Output current $t_{AMB}=40^{\circ}C$	2,1A - see graph 1.
Voltage adjustment range	12V ÷ 15V DC
Ripple voltage	100mV p-p max.
Short-circuit protection SCP	electronic, automatic recovery
Overload protection OLP	105 ÷ 150% of power supply, automatic recovery
Surge protection	varistors
Overvoltage protection OVP	>16V (automatic return)
Optical signalisation	green LED – presence of DC voltage
Operation conditions	2-nd environmental class, temperature: $-10^{\circ}C \div +40^{\circ}C$ relative humidity 20%...90%, without condensation
Dimensions	L=129, W=98, H=38 [+/- 2mm]
Net/gross weight	0,40kg / 0,43kg
Protection class PN-EN 60950-1:2007	I (first) – requires a protective conductor (PE)
Connectors	power-supply: $\Phi 0,63-2,50$ (AWG 22-10) outputs: $\Phi 0,63-2,50$ (AWG 22-10)
Electrical strength of insulation: - between input (network) circuit and output circuits of power-supply (I/PO/P) - between input circuit and PE protection circuit (I/P-FG) - between output circuit and PE protection circuit (O/P-FG)	3000 V/AC min. 1500 V/AC min. 500 V/AC min.
Insulation resistance: - between input circuit and output or protection circuit	100 M Ω , 500V/DC
Storage temperature	$-20^{\circ}C...+60^{\circ}C$
Vibrations and impulse waves during transport	according to PN-83/T-42106

* In order to extend the life of the power supply, the load current of 2,1A is recommended.

* See graph 1.

1.3. Output current vs temperature.

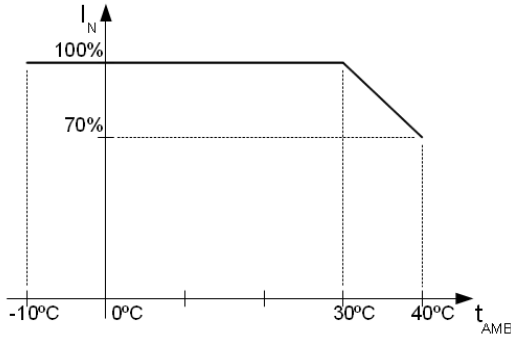

Graph 1.
Allowable output current from the power supply depending on ambient temperature (instantaneous load).

2. Installation.

2.1. Requirements.

The power supply shall be mounted by the qualified installer having appropriate (required and necessary for a given country) permissions and qualifications for connecting (operating) low-voltage installations. The unit shall be mounted in closed rooms, according to the environment class II, of the normal air humidity (RH=90% max. without condensation) and the temperature within the range from -10°C to +40°C.

The power supply shall be mounted in a close casing (a cubicle, a terminal device) and in order to fulfill LVD and EMC requirements the rules for power-supply, encasing and shielding shall be observed according to application.

Due to the power supply design, the PE wire has to be connected to the corresponding connector of the supply unit. Operation without proper grounding of the power supply is not allowed!

2.2. Installation procedure.

1. Prior to installation of the power supply unit, make sure that power leads have been disconnected from the 230VAC mains.
2. Install the unit in the previously selected place.
3. Connect the 230VAC power leads. Connect the PE cable (yellow-green) to an appropriate terminal on the power supply unit (marked with \perp).



**The circuit of the shock protection shall be performed with a particular care, i.e. the yellow and green protection wire of the power cable shall be connected from one side to the terminal marked by the symbol of \perp in the casing of the power-supply. Operation of the power-supply without the properly made and fully operational circuit of the shock protection is UNACCEPTABLE!
It can result in failure of devices and electric shock.**

4. Connect load/loads to proper output connectors of the power supply (positive end is marked as +V, negative end as -V).
5. Upon the completion of tests and trial activation, close the housing, cabinet etc.

2.3. Description of terminal.

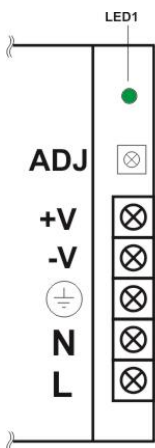

Fig.1. Description of terminal.

Elements/connectors [Fig.1]	Description
L, N, \perp	L-N - input voltage connectors 230V AC, \perp - protective conductor connector
-V	Power supply output (0V)
+V	Power supply output (+12V)
LED1	LED signals the presence of voltage at the unit's output
ADJ	Potentiometer - output voltage adjust

2.4. Dimensions and fitting of the PS-401230 power supply.

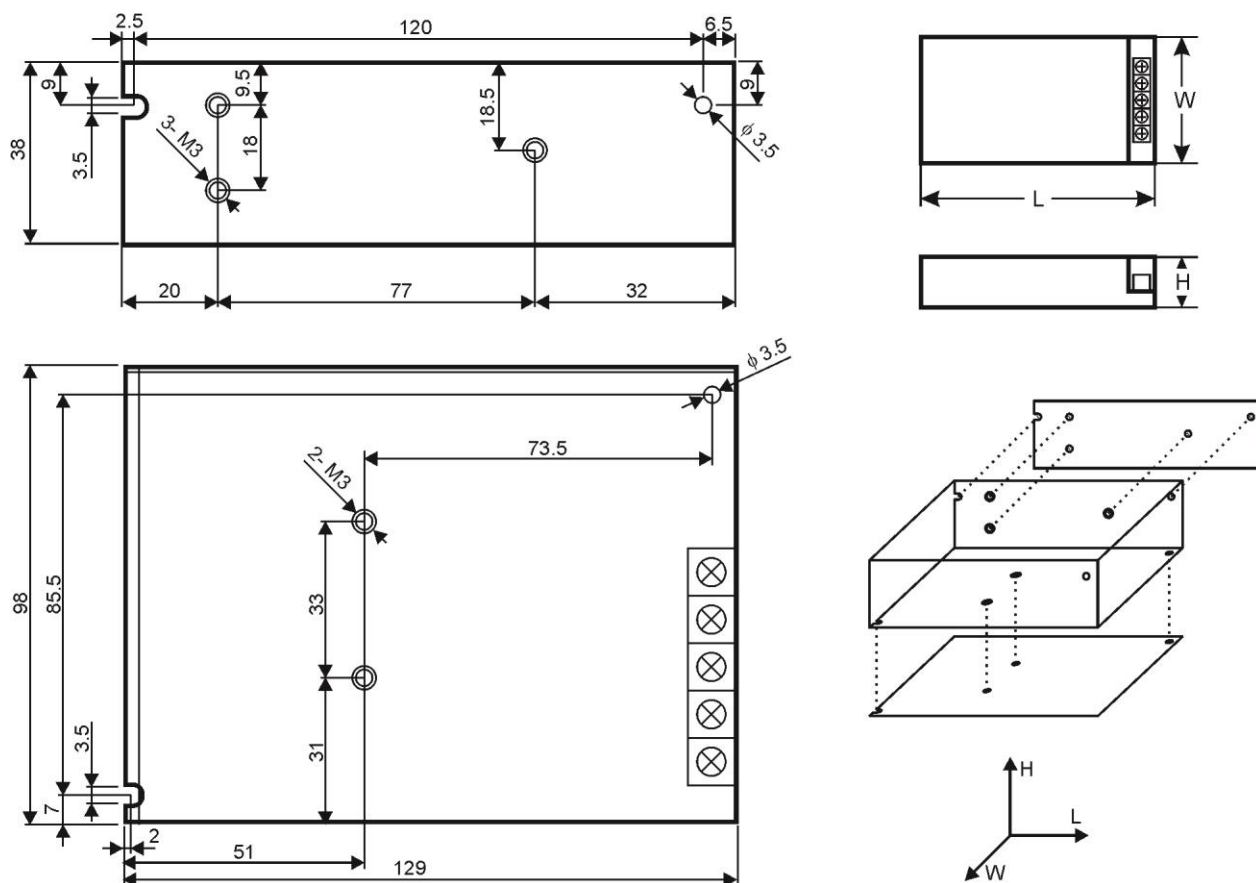

Fig. 2. Dimensions of power supply.

3. Maintenance.

All maintenance procedures can be performed after the disconnection of the power supply from the electrical grid. The power supply does not require any special maintenance procedures, but in the case of significant dust accumulation, dusting using compressed air is recommended.



WEEE designation

The waste electric and electronic equipment worn out may not be disposed of together with standard household waste. According to the WEEE directive, applicable in the EU, the separate neutralization methods should be used for electric and electronic equipment.

Pulsar

Siedlec 150, 32-744 Łapczyca, Poland
Tel. (+48) 14-610-19-40, Fax. (+48) 14-610-19-50
e-mail: biuro@pulsar.pl, sales@pulsar.pl
http:// www.pulsar.pl, www.zasilacze.pl