



# AWOP-225PR v.1.0

## Distribution Junction Box 2x2,5mm<sup>2</sup>

Edition: 3 from 18.09.2014  
Supersedes the edition: 2 from 10.04.2014



Technical approval CNBOP-PIB  
No. AT-0601-0422/2014  
Certificate of accordance CNBOP-PIB  
No. 2966/2014

EN\*



### 1. Description.

The junction box for fire alarm systems is designed for connecting fire protection devices in cable installation systems with fire resistance according to the DIN 4102-12 standard, where the uninterrupted power supply or transmission of the signal in case of fire is required.

The junction box is designed to guarantee the mechanical ability to keep the cable routes capable of guaranteeing the uninterrupted power supply and transmission of telecommunication signals in the fire zone.

The junction box can be used for power supply of fire protection equipment, such as ventilators and smoke vents, fire alarm control panels, emergency warning systems, etc.

Table 1. Elements of the junction box.

Component No.	Description
[1]	Mounting holes for mounting to a surface.
[2]	Cable glands.
[3]	Protection connector PE.
[4]	Connection sockets.

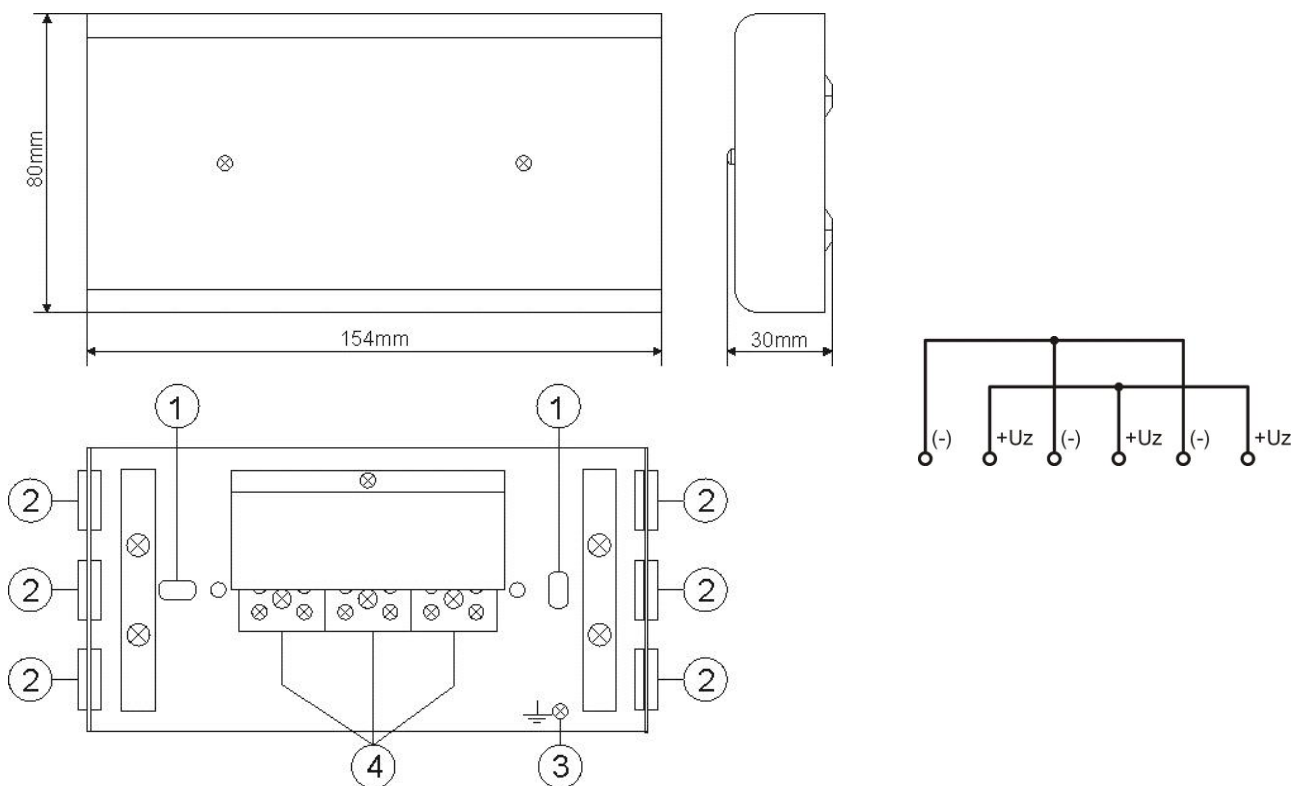

Fig.1. The junction box and wiring diagram.

**Table 2. Technical parameters.**

<b>Voltage</b>	450V AC max
<b>Diameter of installation cable</b>	Max. 10mm
<b>Cross-section of the cable</b>	Max. 2,5mm <sup>2</sup>
<b>Protection class</b>	IP20
<b>Enclosure</b>	DC01 1mm steel plate, color RAL 3001 (red)
<b>Dimensions</b>	154 x 80 x 30 [mm] (WxHxD)
<b>Temperature range during installation</b>	-25°C for +60°C
<b>Mounting</b>	100mm Φ5,5 mm
<b>Net/gross weight</b>	0,37kg /0,40 kg

**2. Installation.**

The junction box for fire alarm systems should be mounted directly to the concrete base class min. B20 or natural stone. Other building materials of adequate strength and of fire resistance class of at least R90 are also approved for use.

The junction box for fire alarm systems should be mounted to the ceiling or wall using two steel pins of adequate fire resistance. The cables should be mounted using handles at intervals of 600 mm. Mounting distance between the cables (handles) and the edge of the junction box is maximally 100 mm.

Pay attention to the following boundary conditions:

- a) The bushings and expansion bolts should be recessed at least 30 mm into the concrete.
- b) Tension on the pin should not exceed 500 N.
- c) Alternatively, the pins with well-documented fire protection design can also be used.
- d) It should be ensured that the functional class of the cable assemblies containing junction boxes for fire alarm systems will not be adversely affected by falling building elements.

Installation cables should be led through the appropriate bushings and then mounted with cable holders located inside the enclosure.

**WEEE LABEL**

Waste electrical and electronic equipment must not be disposed of with normal household waste. According to the European Union WEEE Directive, waste electrical and electronic equipment should be disposed of separately from normal household waste.

**WARRANTY**

24 months from the date of purchase, 36 months from the production date.  
WARRANTY IS VALID only upon presentation of the original invoice.

**Pulsar**

Siedlec 150, 32-744 Łapczyca, Poland  
Phone (+48) 14-610-19-40, Fax. (+48) 14-610-19-50  
E-mail: [biuro@pulsar.pl](mailto:biuro@pulsar.pl), [sales@pulsar.pl](mailto:sales@pulsar.pl)  
http:// [www.pulsar.pl](http://www.pulsar.pl), [www.zasilacze.pl](http://www.zasilacze.pl)