

Seismic Vibration Detector SC100





Planning and Installation

User Guide

- To get the best use of the product, please read the User Guide carefully before using the product.
- Keep the User Guide in an easily accessible place and make it available to the next user.

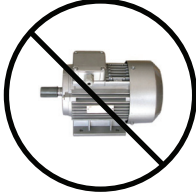
TO THE INSTALLER

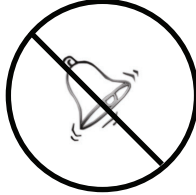
Before planning and installing the Seismic Vibration Detector SC100, please consider the following installation requirements:

 <p>Electrical Devices</p> <p>Do not install the detectors close to electrical devices (such as electric motors, transformers, fans, air conditioners, etc.), which may create mechanical vibrations in the protected structure.</p> <p>Avoid mechanical contact between such devices and the protected surface, or use appropriate insulating materials to reduce the vibrations.</p>	 <p>Water piping</p> <p>Do not install the detectors close to water piping.</p> <p>The flow of water through piping, when in mechanical contact with the protected structure, emits a strong signal in the structure itself, which may cause false alarms.</p>
 <p>Bells</p> <p>Do not install the detectors close to the bells.</p> <p>Do not apply pieces of tape on the bell to suppress the overtones generated in the frequency range of the detectors.</p>	 <p>Human activity</p> <p>DO install carpet or vibration damping material on vaults and under safes placed on concrete or marble floors.</p>

Regular maintenance and inspection (at least annually) by the installer and frequent testing by the user are vital to continuous satisfactory operation of any product.

The installer should assume the responsibility of developing and offering a regular maintenance program to the user, as well as acquainting the user with the proper operation and limitations of the product and its component parts. Recommendations must be included for a specific program of frequent testing to insure the product's operation at all times.

LIMITED WARRANTY

WARRANTY INFORMATION

For the latest warranty information, please go to:
www.honeywell.com/security/hsc/resources/wa

Contents

- TO THE INSTALLER i
- LIMITED WARRANTY ii
- 1 About This Document 1
 - Overview of Contents 1
 - Special Font and Symbols 1
 - How to Use This Document 1
- 2 Introduction 2
 - Overview of the Detector 2
 - Applications 2
 - Features 3
- 3 Function Description 4
 - Function Criteria 4
 - Detection Parameters 4
 - Alarm Criteria 4
 - Function Modules 4
 - Sensor Element 4
 - Signal Conditional Block 4
 - Switch Block 5
 - Micro Controller Block 5
 - Output Alarm Block 5
 - Power Supply Block 5
 - Sabotage Protection 5
- 4 Basic Accessories 6
- 5 Planning Protection 7
 - Vaults 7
 - ATMs and Night Deposit Safes 9
 - Free Standing Safes 9
 - Filing Cabinets 10
 - Document Cabinets 10
 - Gates 11
 - Hatches and Chests 11
- 6 Installation 12
 - Mounting the Detector 12
 - Opening the Detector 12
 - Mounting on Steel 12
 - Mounting on Stainless Steel or Hardened Steel 13
 - Mounting on Concrete 14
 - Mounting the Accessories 15
 - The Movable Mounting Kit SC111 15
 - The Keyhole Protection Kit SC112 15
 - The Spacer for Keyhole Protection Kit SC118 16
 - The Armored Cable Kit SC114 16
 - The Test Transmitter SC113 16
 - The External Test Transmitter SC115 16
 - The Recess Mounting Box SC116 17
 - The Floor Mounting Box SC117 17
- 7 Settings 18
 - DIP Switch Settings 18
 - EOL Jumper Settings 19
 - J19/J20 Settings 19
 - J1 Setting 19
- 8 Connecting the Detector 20
- 9 Test 21
 - Field Test 21
 - Control and Function Test 22
 - Remote Test (Alternative) 22
- 10 Technical Specifications 24

Figures

Figure 2-1 Detector Description	2
Figure 5-1 Planning Vault Protection.....	7
Figure 5-2 Layout Plan.....	8
Figure 5-3 Detector mounted on the center of one modular vault.....	8
Figure 5-4 Detector mounted between two modular vaults.....	8
Figure 5-5 Planning ATM Protection	9
Figure 5-6 Planning Night Safe Deposit Box Protection	9
Figure 5-7 Detectors mounted on the outside of the Safe	10
Figure 5-8 Planning Filing Cabinet Protection	10
Figure 5-9 Planning Document Cabinet Protection.....	11
Figure 6-1 Opening the Detector.....	12
Figure 6-2 Drill Plan.....	12
Figure 6-3 Mounting Plate SC110.....	13
Figure 6-4 Movable Mounting Kit SC111 Components.....	15
Figure 6-5 Keyhole Protection Kit SC112 Components.....	15
Figure 6-6 Spacer for Keyhole Protection Kit SC118 Components.....	16
Figure 6-7 Armored Cable Kit SC114 Components.....	16
Figure 6-8 Test Transmitter SC113 Components.....	16
Figure 6-9 External Test Transmitter SC115 Components.....	16
Figure 6-10 Recess Mounting Box SC116 Components	17
Figure 6-11 Floor Mounting Box SC117 Components	17
Figure 7-1 Function modules on Detector Base	18
Figure 8-1 Wiring on the terminal block.....	20
Figure 8-2 Alarm and tamper configured to one loop	20
Figure 8-3 Alarm and tamper configured to two loops	20

Tables

Table 2-1 Application Settings	2
Table 9-1 Remote Test.....	23

1 About This Document

Thank you for purchasing Honeywell Seismic Vibration Detector SC100.

This guide is designed to be a reference for the planning and installation of the Seismic Vibration Detector SC100.

Overview of Contents

This document contains the following chapters:

- *Chapter 1, About This Document*, gives a brief introduction of “Seismic Vibration Detector SC100 Planning and Installation User Guide”.
- *Chapter 2, Introduction*, provides general information about the Seismic Vibration Detector SC100, applications and features.
- *Chapter 3, Function Description*, introduces the function criteria and function modules of the Seismic Vibration Detector SC100.
- *Chapter 4, Basic Accessories*, lists all basic accessories used with the Seismic Vibration Detector SC100.
- *Chapter 5, Planning Protection*, gives instructions on placement planning for the Seismic Vibration Detector SC100 in different applications.
- *Chapter 6, Installation*, describes how to install the Seismic Vibration Detector SC100 and related accessories.
- *Chapter 7, Settings*, shows how to configure sensitivities and other settings on the Seismic Vibration Detector SC100 base.
- *Chapter 8, Connecting the Detector*, illustrates how to wire and connect the Seismic Vibration Detector SC100 to the protected zone.
- *Chapter 9, Test*, describes important installation and function tests for the Seismic Vibration Detector SC100.
- *Chapter 10, Technical Specifications*, provides technical specifications of the Seismic Vibration Detector SC100.

Special Font and Symbols

<i>Italic</i>	references
Note	important information
Caution	important operation warning

How to Use This Document

- Illustrations in the manual are for reference only; please see the actual items.
- Product modifications and updates may be made at any time without notification.
- Please read the manual before operation and keep it for future reference.

2 Introduction

Overview of the Detector

The Seismic Vibration Detector SC100 is a universal seismic or structural vibration detector designed to detect selected vibrations from burglary or intrusion attempts on high value storage units, such as Vaults, Doors, ATMs, Safes and other solid structures.

The detector consists of a sensor element to convert mechanical vibrations to electrical signals, a signal conditional block, micro controller block, output alarm block, tamper protection, and a switching block for selecting detector settings, all in a miniature metal housing.

Figure 2-1 Detector Description

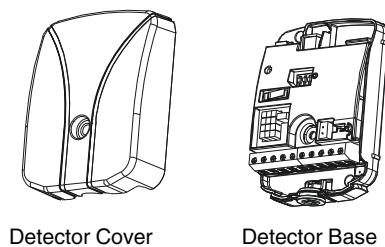

Detector Cover

Detector Base

Applications

The Seismic Vibration Detector SC100 is designed to detect any known attack tool on:

- Vaults (Vault Doors, Strong Room Vaults, Modular Vaults)
- ATMs
- Night Deposit Safes
- Free Standing Safes
- Gates
- Hatches
- Chests
- Other objects with a solid structure

Depending on the vibration characteristics of the application construction, sensitivity required in each sensor, and the natural vibrations and ambient noise level in the premises, the detection ranges of the Detector SC100 should follow the parameters in the table below.

Table 2-1 Application Settings

Sensitivity Settings	Material	Detection Radius	Applications	Noise Level
G_{high}	Concrete (K350)	5.0m (16.4 ft.)	Vaults, Safes and ATMs (advised for grade 4 to 6)	Insignificant noise level
G_{normal}	Concrete (K350)	2.5m (8.2 ft.)	Vaults, Safes and ATMs	Moderate noise level
	Steel	4.0m (13.1 ft.)		
G_{low}	Concrete (K350)	1.5m (4.9 ft.)	Free Standing Safes, Night Deposit Safes, ATMs and Chests	Considerable noise level
	Steel	2.0m (6.6 ft.)		

Sensitivity Settings	Material	Detection Radius	Applications	Noise Level
G _{noisy}	Steel	1.5m (4.9 ft.)	Free Standing Safes, Night Deposit Safes, ATMs and Chests with excessive noise (internal or external)	Heavy noise level

- Note**
- Sensitivity settings (G_{high}, G_{normal}, G_{low}, G_{noisy}) are defined in “DIP Switch Settings” on page 18.
 - The parameters in the table above are for reference only and they may vary according to the quality of the material.
 - The detection range will be reduced if cracks and joints exist in the material.

Features

The Seismic Vibration Detector SC100 has the following features:

- 24-hour detection of all known attack tools on Vault, Doors, Safes, ATMs, etc.
- Flat frequency non-resonant response sensor for genuine frequency analysis.
- Built-in diagnostic tool used to set detector sensitivity in relation to existing noise level.
- DIP switch sensitivity settings to adapt to various applications.
- Integrated EOL resistors compatible with various control panels.
- High detection capability due to new sophisticated signal handling and incorporated computer algorithms.
- Low current consumption.
- Solid state change over alarm relay.
- Multipurpose accessories provided with multiple applications.
- Standard drill sheet protection.
- Rate of Rise and temperature alarm.
- Miniature metal housing – easy to fit in restricted spaces.
- Approved by IMQ type 3, cULus, CE, and CCC.

3 Function Description

Function Criteria

Detection Parameters

The detection function of the Seismic Vibration Detector SC100 is based on the structural vibrations generated on the protected surfaces upon an attempt to break through the physical barriers.

Vibrations detected comprise four important parameters:

- signal strength (amplitude)
- signal frequency (spectra)
- signal duration
- structure of duration

These parameters differ between real attacks and "normal" background vibrations and will be detected and analyzed by the detector before an alarm is triggered. The characteristics below represent signals that can be detected by the Detector SC100:

- Signals with very high amplitude and short duration, which can be generated by explosives.
- Signals with medium to high amplitude and medium to long or intermittent duration, which can be generated by mechanical demolition tools.
- Signals with wide frequency spectra, low amplitude and long duration, which can be generated by thermal attacks.

Alarm Criteria

The signals detected will be analysed by several parallel software detection modes with specific algorithms for detection of known attack methods and tools as described as below:

- **The low level detection mode** is designed to recognize low to medium amplitude signals with long duration, like those caused by a thermic lance, oxy-arc or acetylene torch.
- **The medium level detection mode** is designed to detect medium to high amplitude and medium to long or intermittent duration signals as caused by mechanical demolition, such as hydraulic jack, hammer, chisel and electric power tools.
- **The high level detection mode** is designed to detect very high amplitude and short duration signals as caused by explosives.

The signal from the sensor is fed to the signal conditioning block and further to the micro controller for evaluation. An alarm signal will be sent to the output alarm block when a condition with sufficient signal strength, frequency spectra and signal duration is achieved.

Function Modules

Sensor Element

The Seismic Vibration Detector SC100 includes a sensor element that converts mechanical vibrations into electrical signals. These signals provide a non-resonant flat frequency response for genuine signal analysis, which is used for detection of structural vibrations caused by attacks against the protected surface. These signals will be analyzed in different software detection modes.

Signal Conditional Block

The electrical signal the sensor converted is fed to the signal conditional block that adapts the signal for further analysis. It also contains circuits for supply voltage and temperature supervision (see *Alarm Criteria* on page 4). This block also generates test signals for the Test Transmitter SC113.

Switch Block

This block contains the DIP switches for sensitivity settings, application settings and the noise LED settings, further communicating with the micro controller and signal conditional blocks.

Micro Controller Block

This block is the heart of the Detector SC100. It handles functions for signal analysis and recognition, circuit supervision of power supply and temperature, noise recognition and indication, test and sensitivity reduction, etc.

It also contains a watchdog function which is used to detect system lockups and create an alarm signal to the output alarm block. This block contains nano watt technology and the software code stored in a flash program memory with code protection.

Output Alarm Block

The circuits in the output alarm block will be activated by the micro controller block when intrusion attack signals are recognized. The alarm output provides two forms of alarm signals:

- One potential free solid state SPDT change over relay.
- One open collector transistor output, going into conductive mode upon alarm condition.

The transistor is protected against overload with a series resistor of 1.38k Ohm.

Note No protection against sabotage attempts with external magnetic fields is needed due to solid state alarm relay.

Power Supply Block

The input circuits are very well protected against electrical interference and high energy electrical surges by filtering, transient absorber and spark gaps. The small mechanical dimensions, circuit board layout and design, results in very good resistance against RFI from various transceivers, cell phones and so on. The Detector SC100 has a wide supply voltage range from 8 to 16 VDC due to the low internal system voltage of 5 Volt.

Sabotage Protection

The Seismic Vibration Detector SC100 has a full range of tamper protection features, thus an alarm will be given when an attempt is made to:

- Pry off the detector from the protected surface
- Open the detector
- Disable the detector by heat
- Lower the supply voltage below 6.5V

The Detector SC100 is equipped with a stainless steel drill shield that makes it difficult to drill into the detector and at the same time generates strong vibrations.

4 Basic Accessories

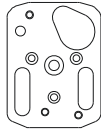

Mounting Plate SC110

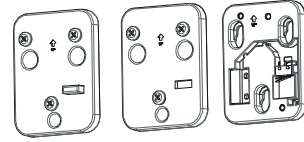

Movable Mounting Kit SC111

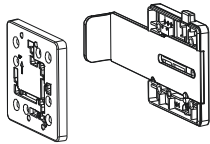

Keyhole Protection Kit SC112



Test Transmitter SC113

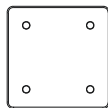

Spacer for Keyhole Protection Kit SC118

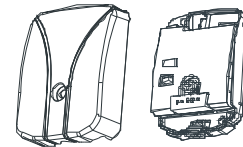

External Test Transmitter SC115

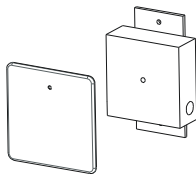

Recess Mounting Box SC116

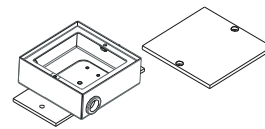

Floor Mounting Box SC117



Armored Cable Kit (8 wires) SC114

5 Planning Protection

Before mounting the detector, carefully plan the mounting locations to achieve an extremely high security level.

In general, the detectors should be mounted at the center of the detection range (see *Table 2-1 Application Settings* on page 2.) or positioned where most of the attacks are likely to be aimed.

Caution Please read *TO THE INSTALLER* on page *i* before planning the installation.

Vaults

Recommended detector mounting locations for vaults, including vault doors, strong room vaults and modular vaults:

- On each wall
- On the floor
- On the ceiling inside the vault
- On or inside the vault door

Figure 5-1 Planning Vault Protection

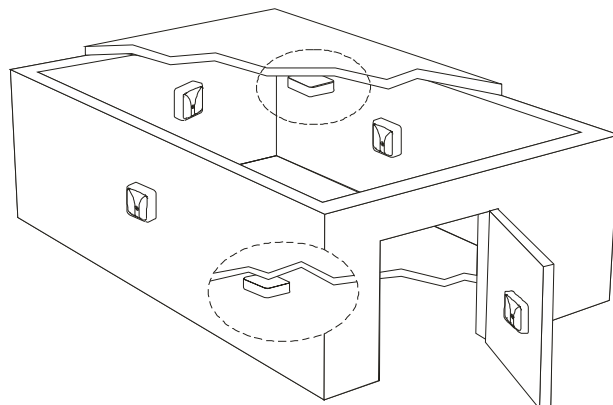

The Mounting Plate SC110, the Recess Mounting Box SC116 and the Floor Mounting Box SC117 can be used to mount the detectors in the vaults. Mounting detectors at least 1,80m high to keep clear from lockers is recommended.

The sensitivity of the detectors can be set to G_{high} or G_{normal} , depending on actual applications.

Layout Plan

A layout plan is used to help define the location of detectors mounted in the vaults. It is recommended to prepare a layout plan before mounting the detectors according to the actual construction. The figure below shows a sample for a 7 x 5 x 3 meter (23 x 16.4 x 9.8 ft) sized vault..

Figure 5-2 Layout Plan

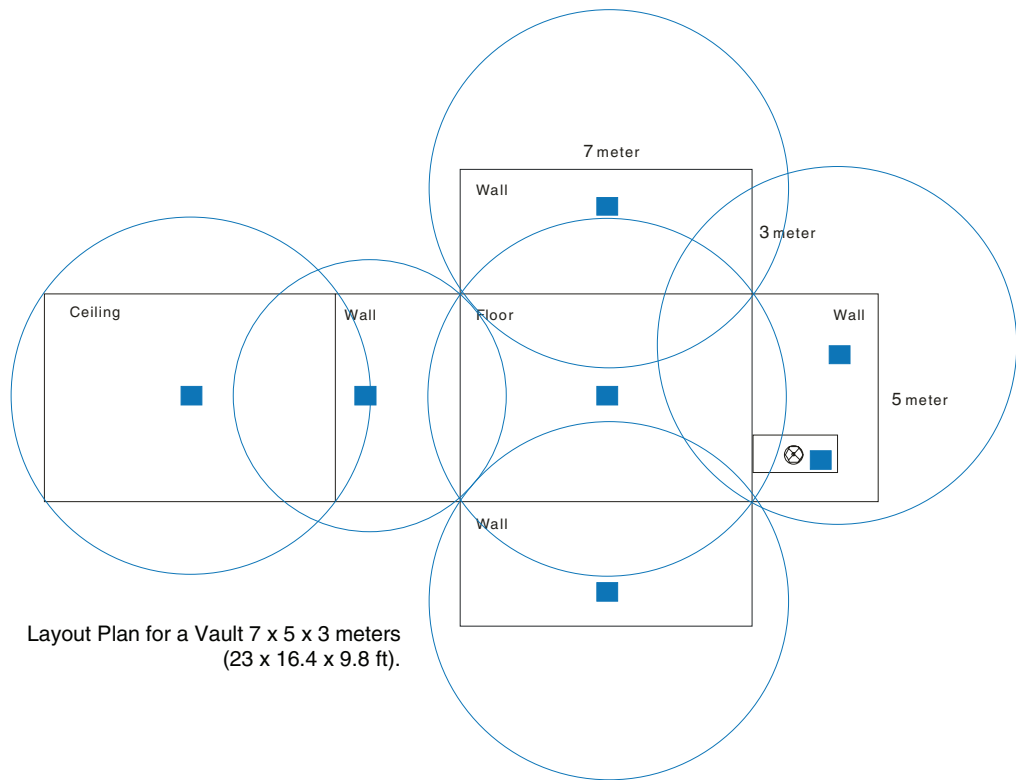

Layout Plan for a Vault 7 x 5 x 3 meters
(23 x 16.4 x 9.8 ft).

Planning Guidelines

- The detection range will be reduced if joints or cracks exist in the vault, corners, between walls and floor, and/or on the ceiling. In these cases install detectors on both sides of the irregularity found.
- The vault door can be protected by directly mounting a detector inside the door leaf or outside the door. For this application, use the Movable Mounting Kit SC111 or the Keyhole Protection Kit SC112.
- When installing the detectors in an existing vault, mount a detector on the door frame to protect the walls on either side of the door and partly the vault door.
- Modular Vaults must be bolted and welded together to get a reasonable detection range.
- One maximum module [width is 1000mm (39.37 in.) and length is 6500mm (255.9 in.)] can be covered on the other side of a welded corner.
- A detector mounted on the center of one module can cover 5 adjacent modules at most.

Figure 5-3 Detector mounted on the center of one modular vault



- A detector mounted on a welded mounting plate between two modules can cover 6 adjacent modules at most.

Figure 5-4 Detector mounted between two modular vaults



- Before reducing the sensitivity where noise level is high, the noise source should first be removed.
- Drill tests should be performed on the outside of the vault.

Note

This guideline is typically recommended for detector mounting and should always to be followed up by practical sensitivity and noise checks before the installation is completed.

ATMs and Night Deposit Safes

ATMs and Night deposit safes are frequently exposed to human made noise as well as extensive internal noise. The recommended application setting for ATMs is to set DIP switch 3 to the OFF position.

For both ATM and night deposit safes we recommend mounting:

- At least one detector on or inside the safe cabinet, close to the dispenser opening.
- One detector on the door, close to or between the hinges or inside the door leaf.

Figure 5-5 Planning ATM Protection

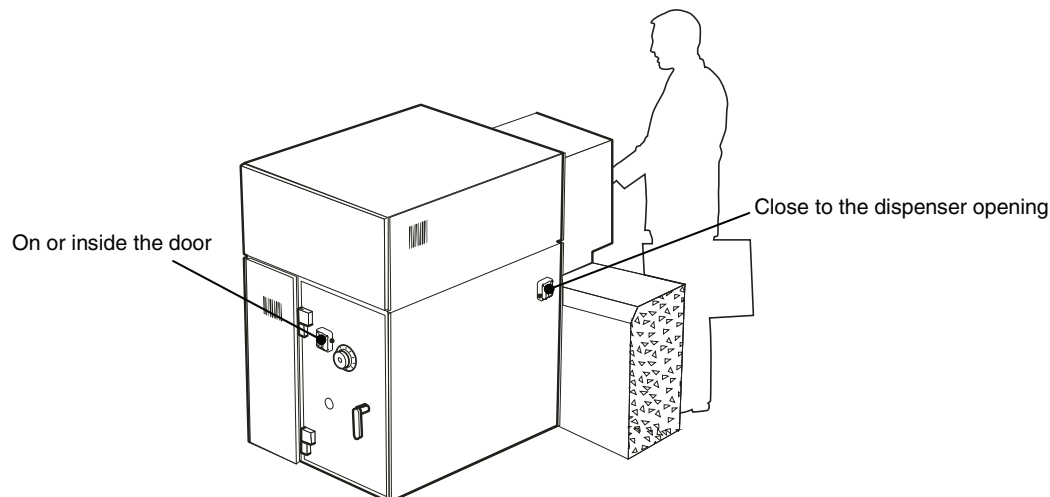
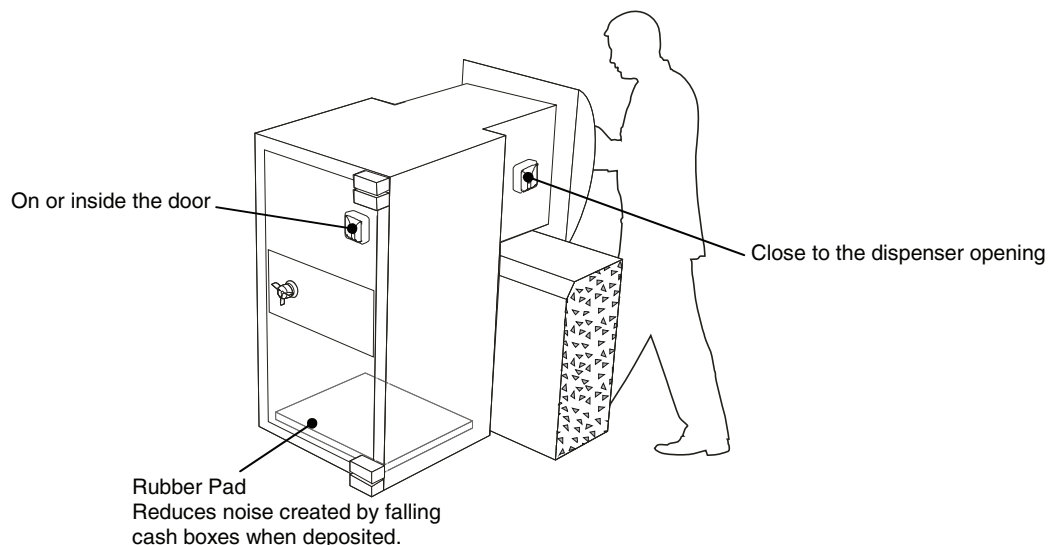

Figure 5-6 Planning Night Safe Deposit Box Protection



The Movable Mounting Kit SC111 or the Keyhole Protection Kit SC112 and the Armored Cable Kit SC114 can be used when mounting detectors on the safes.

Free Standing Safes

The signal transmission from an attack is often very poor between the door and the cabinet of a safe, therefore we recommend mounting two detectors (inside or outside):

- On the body
- On the door

Detectors mounted inside

Inside of the safe, we recommend mounting detectors:

- At the hinge side, close to the upper hinge of the safe cabinet.

Planning Protection

- Inside of the door leaf as close as possible to the lock mechanism or to the hinges.

The Armored Cable kit SC114 should be used when mounting a detector on/in the door and for added protection, a magnetic contact should be added on the door. Cable outlet options are normally provided in new safes. If not, mount the detectors on the outside.

Detectors mounted outside

Outside of the safe, we recommend mounting one detector:

- On the side of the safe, close to the hinge

And the other detector can be mounted on the door in three different ways:

- Close to the hinge, providing a short distance with the Armored Cable Kit SC114.
- Close to the lock, mounted on the Keyhole Protection Kit SC112.
- In such way that the cable prevents opening the door when the detector is on the night position plate, mounted with the Movable Mounting Kit SC111.

Figure 5-7 Detectors mounted on the outside of the Safe

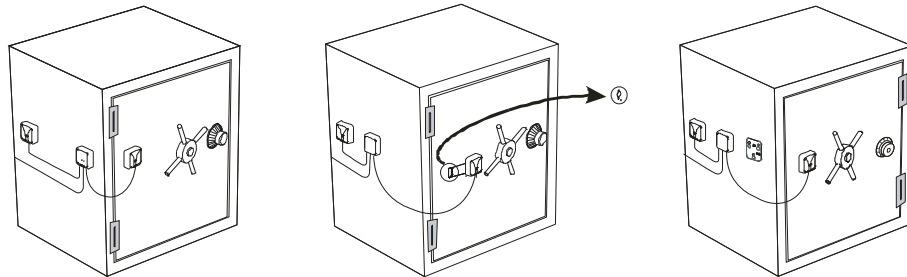

Detectors are better protected when mounted inside, and detectors mounted outside will have a deterring effect.

The Movable Mounting Kit SC111 and the Keyhole Protection Kit SC112 have the advantage of forcing the staff to handle the alarm installation properly. It prevents the staff forgetting to remove keys or close the safe doors properly and blocks the keyhole from being loaded with explosives.

Filing Cabinets

Mounting the detector as close as possible to the lock mechanism on one side of the cabinet is recommended. The Movable Mounting Kit SC111 can also be mounted on a drawer that has a higher security requirement. See [Figure 5-9 Planning Document Cabinet Protection](#) for reference.

Figure 5-8 Planning Filing Cabinet Protection

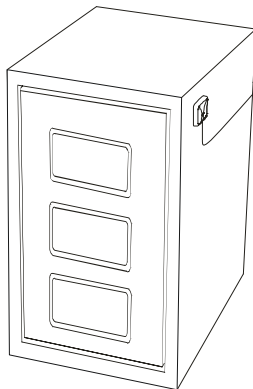

Document Cabinets

For document cabinets, it is best to mount the detector inside or outside on the top surface at the front, close to or between where the door bolts come up.

Also, in high security applications, using a Movable Mounting Kit SC111 on the door is recommended.

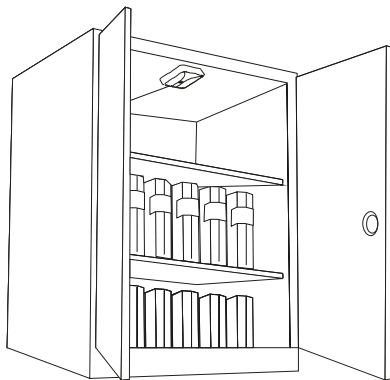
Figure 5-9 Planning Document Cabinet Protection**Note**

Document and filing cabinets have thinner steel surfaces which act as a membrane for acoustic (sound) waves. Before leaving the installation site, check carefully to ensure the sensitivity is not set too high.

Gates

For Gates, particularly Industrial Gates, which are made of steel, mounting the detector on the upper part of the frame into which the vertical rods are welded is recommended.

A weather protection box (which can be purchased from an electrical equipment wholesaler) should be used to protect the detector from moisture. The detector must be in direct metallic contact with the gate by using screws or a welded mounting plate.

Hatches and Chests

For protection of Hatches and Chests, normally one detector is mounted inside the Hatch or Chest door and one additional detector is mounted inside the chest cabinet if it consists of a solid structure like concrete or steel.

6 Installation

Mounting the Detector

The Seismic Vibration Detector SC100 can be mounted on any solid surface and is most commonly used on Steel, Stainless Steel, Hardened Steel and Concrete.

- Caution**
- Please read *TO THE INSTALLER* on page *i* before mounting the detector.
 - Before the installation is completed, make sure the sensitivity setting is correct and the noise level is considered.
 - The detector should not be mounted on cinder block or other unproved masonry surfaces.

Opening the Detector

Before mounting the detector, remove the top screw to separate the detector cover from the detector base.

Figure 6-1 Opening the Detector

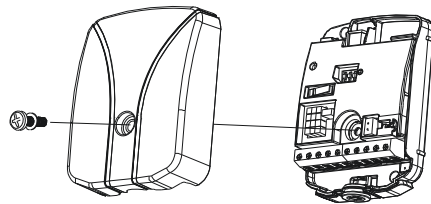

Note: The top screw is only used for securing the cover, so do not tighten it too much when mounting the detector.

Mounting on Steel

When mounting the detector on a flat, smooth steel surface, both the Drill Plan (see *Figure 6-2 Drill Plan*) and the Detector Base (see *Figure 2-1 Detector Description*) can be used to mark the mounting holes.

Figure 6-2 Drill Plan

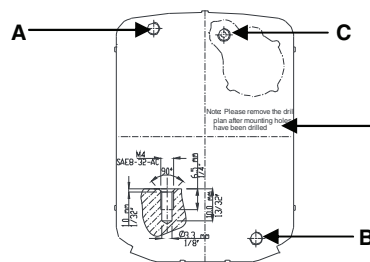

A, B - Detector SC100 mounting holes
C - Test Transmitter SC113 mounting hole

Note: The drill plan must be removed after all of the mounting holes have been drilled.

Refer to the steps below to mount the Detector SC100 on steel.

1. Attach the Detector Base or Dill Plan on the mounting area, and then mark the outline and center punch the detector mounting holes A, B and test transmitter mounting hole C.
 2. Remove the Drill Plan or Detector Base, and then thoroughly remove the paint in the outline marked on the mounting area.
- Note:** The remnant Drill Plan or paint will significantly weaken the sensitivity.

	<p>Notes:</p> <ul style="list-style-type: none"> • The detector base cannot be used to mark test transmitter mounting hole C. • Skip marking hole C if a Test Transmitter SC113 is not used. 	
--	---	--

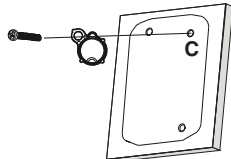
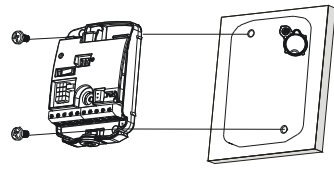
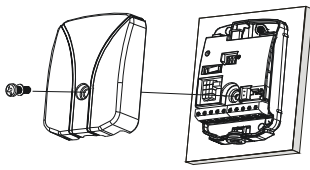
<p>3. Drill the detector mounting holes A, B [Ø 3.3mm (0.15 in.) and minimum 8 mm (0.35 in.) deep], and then thread the two holes with a M4 Tap [6mm (0.25 in.) at least].</p> <p>4. Drill the Test Transmitter SC113 mounting hole C [Ø 3.3mm (0.15 in.) and minimum 8 mm (0.35 in.) deep], and then thread the hole with a M4 Tap [6mm (0.25 in.) at least].</p> <p>Notes:</p> <ul style="list-style-type: none"> • Cool the tools with oil while drilling and threading. • Skip step 4 if a Test Transmitter SC113 is not used. 	<p>5. Remove all of the burrs.</p> <p>6. If used, attach the Test Transmitter SC113 on the mounting area (at C) and then use the M4×8mm (0.35 in.) screw to secure it.</p> <p>Note: Skip this step if a Test Transmitter SC113 is not used.</p> 
<p>7. Attach the detector base on the steel surface and then use the two M4×8mm (0.35 in.) screws provided to secure it.</p> 	<p>8. Wire and configure the detector (see the related chapter in this user guide) and after a successful test, use the top screw to secure the detector cover properly.</p> 

Mounting on Stainless Steel or Hardened Steel

When mounting on stainless steel or hardened steel, the Mounting Plate SC110 (**UPSIDE DOWN**) must be used and should be welded on the mounting surface first.

Figure 6-3 Mounting Plate SC110

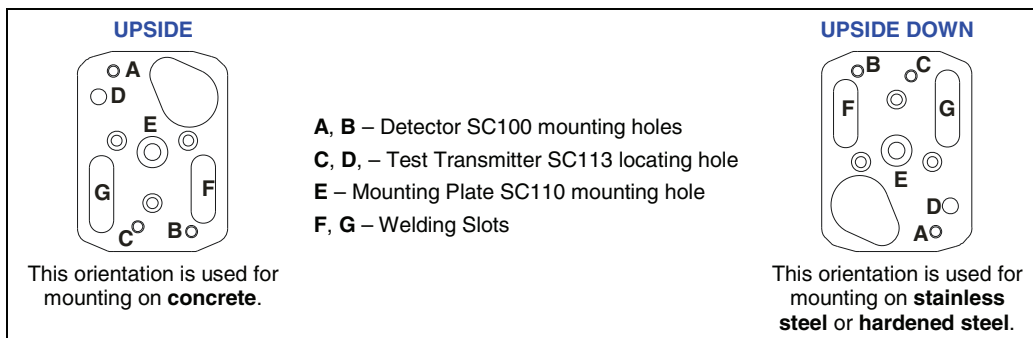

Refer to the steps below to mount the Detector SC100 on stainless steel or hardened steel.

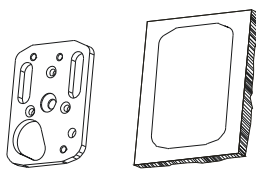
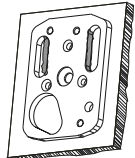
<p>1. Remove paint from the mounting area (especially the welding area).</p> <p>2. Attach the Mounting Plate SC110 on the mounting area, and then mark the outline.</p> 	<p>3. Attach the Mounting Plate SC110 into the outline marked and ensure it cannot move, and then along the INSIDE of the welding slots, weld the Mounting Plate SC110 on the mounting surface.</p> <p>Note: The welding must be done along the INSIDE of the welding slots, otherwise the Mounting Plate SC110 may be distorted.</p> 
<p>4. Tap off slag and remove weld spatter and make sure the whole mounting surface is still flat.</p> <p>5. Attach Test Transmitter SC113 on the mounting plate (at C) and then use the M4×8mm (0.35 in.) screw to secure it.</p> <p>Note: Skip this step if a Test Transmitter SC113 is not used.</p>	

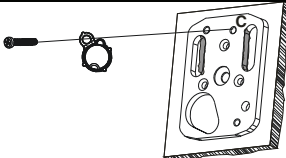
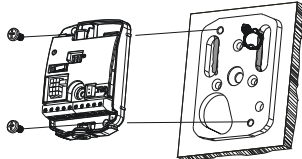
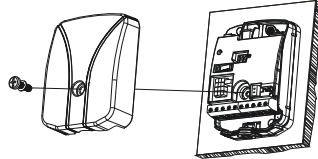
	
<p>6. Attach the detector base on the Mounting Plate SC110 and then use the two M4 × 8mm (0.35 in.) screws provided to secure it.</p>	<p>7. Wire and configure the detector (see the related chapter in this user guide) and after a successful test, use the top screw to secure the detector cover properly.</p>
	

Mounting on Concrete

When mounting on concrete, the Mounting Plate SC110 (**UPSIDE**) must be used (see Figure 6-3).

Caution Mounting the detector directly on a bare or plastered concrete surface will result in low detection sensitivity and may cause damage to the detector.

Refer to the steps below to mount the detector on concrete.

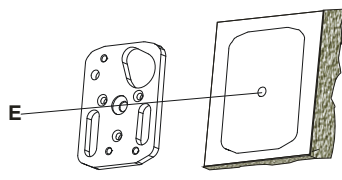
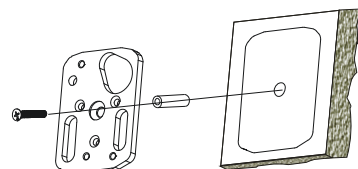
<ol style="list-style-type: none"> 1. Attach the Mounting Plate SC110 on the mounting area and then mark the outline and center hole E. 2. Drill the center hole E of Ø 10mm (0.40 in.) and minimum 65mm (2.6 in.) deep, and then remove all drill residue and plaster. 	<ol style="list-style-type: none"> 3. Insert the M6 anchor into hole E and make sure the anchor can enter into the concrete. Note: Use a longer M6 anchor or a distance sleeve between the Mounting Plate SC110 and the anchor if the M6 anchor cannot reach the solid concrete. 4. Hold the Mounting Plate SC110 in place and install the M6 × 50mm (2 in.) screw in the wall, but do not fully tighten. Note: The Mounting Plate SC110 here can be rotated.
	

Note: Skip step 6 to step 11 if a Test Transmitter SC113 is not used.

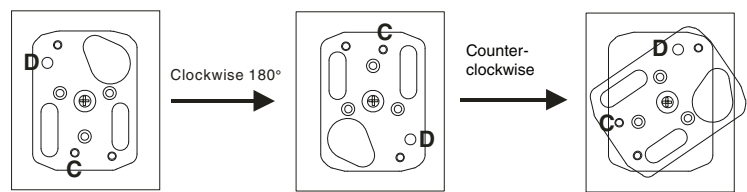
<ol style="list-style-type: none"> 5. Rotate the Mounting Plate SC110 clockwise 180° and mark hole C. 6. Rotate the Mounting Plate SC110 counterclockwise until the mark from hole C can be seen through hole D. Note: Tighten the center screw slightly to stabilize the Mounting Plate SC110 at this position. 7. Through hole D drill a hole of Ø 5.5 mm (0.25 in.) and minimum 25mm (1 in.) deep and then remove all residue. 	
---	--

<ol style="list-style-type: none"> 8. Release and turn the Mounting Plate SC110 to the original orientation. 9. Insert the M4 anchor into the drilled hole and make sure the anchor will enter into the concrete. 10. Attach the Test Transmitter SC113 on the M4 anchor, and then use the M4 × 14mm (0.55 in.) screw to permanently secure it.
--

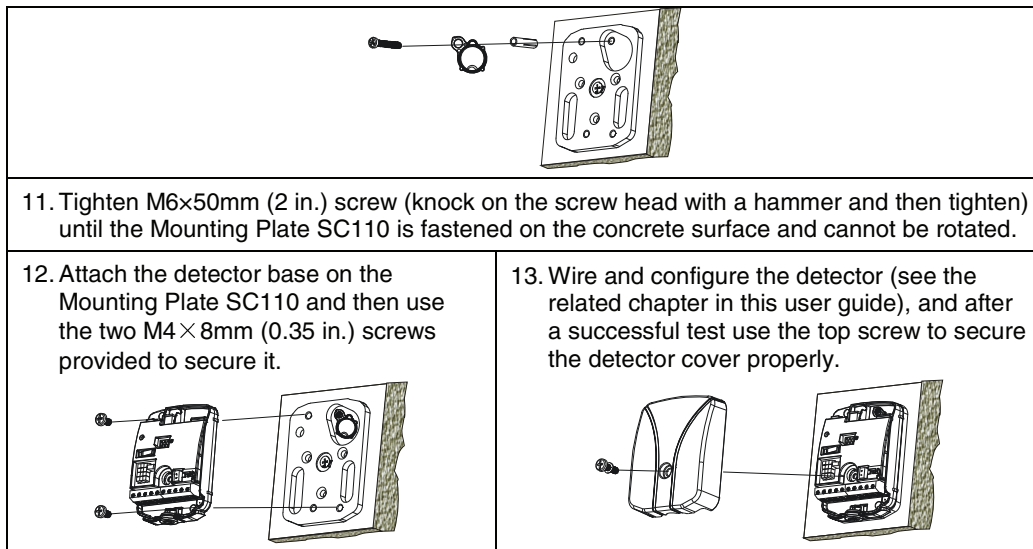

Mounting the Accessories

A full range of mounting accessories for different applications facilitates a wide range of mounting requirements.

The Movable Mounting Kit SC111

The Movable Mounting Kit SC111 consists of one mounting plate on which Detector SC100 is mounted, one Day position plate on which the Detector SC100 is positioned when the system is not armed, and one Night position plate mounted on the protected surface, on which the Detector SC100 is positioned when the system is armed.

The figure below shows the components of the Movable Mounting Kit SC111. For more information, please refer to the *“Movable Mounting Kit SC111 User Guide”*.

Figure 6-4 Movable Mounting Kit SC111 Components

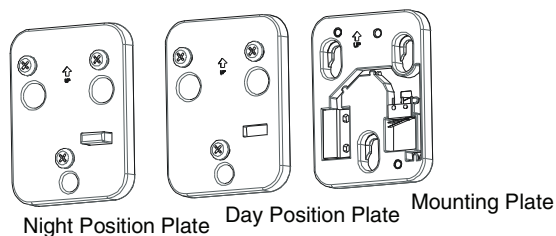

The Keyhole Protection Kit SC112

The Keyhole Protection Kit SC112, used with the Detector SC100, prevents unlocking while the system is armed, prevents loading explosives into the keyhole and is a mounting plate which allows the Detector SC100 to detect intrusion attempts on doors.

The figure below shows the components of the Keyhole Protection Kit SC112. For more information, please refer to the *“Keyhole Protection Kit SC112 User Guide”*.

Figure 6-5 Keyhole Protection Kit SC112 Components

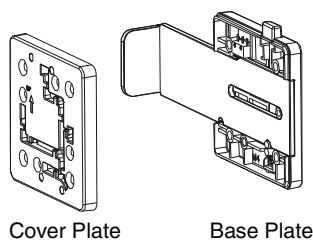

The Spacer for Keyhole Protection Kit SC118

The Spacer SC118 is used with the Keyhole Protection Kit SC112 only if the steel slide on SC112 touches the keyhole collar on the protected surface. For more information, please refer to the *“Keyhole Protection Kit SC112 User Guide”* and *“Keyhole Protection Spacer SC118 User Guide”*.

Figure 6-6 Spacer for Keyhole Protection Kit SC118 Components

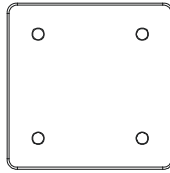

The Armored Cable Kit SC114

The Armored Cable Kit SC114 is designed to provide protection of the detector wiring when the detector is installed on the door or wall of a safe or vault. See *Figure 5-7 Detectors mounted on the outside of the Safe* on page 10 for reference.

The Armored Cable Kit SC114 includes the following items:

- 8 core cable, white
- Flexible stainless steel conduit
- Cable straps

Figure 6-7 Armored Cable Kit SC114 Components



The Test Transmitter SC113

The Test Transmitter SC113 is used for checking the proper mounting, wiring and function of the detector, and it should be mounted inside of the detector. For information on mounting the Test Transmitter SC113, please refer to the *Mounting the Detector* section starting on page 12.

Figure 6-8 Test Transmitter SC113 Components



The External Test Transmitter SC115

The External Test Transmitter SC115 is a range test transmitter developed to check and ensure the mounting and the function of the seismic detector is good. The SC115 generates a simulated attack signal in the protected object with multiple SC100 seismic detectors installed in concrete vaults and all other solid structure value storage units.

The figure below shows the components of the External Test Transmitter SC115. For more information, please refer to the *“External Test Transmitter SC115 Installation Guide”*.

Figure 6-9 External Test Transmitter SC115 Components

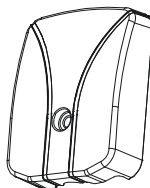

Front Cover

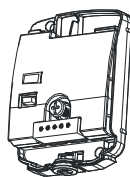

Transmitter Base

The Recess Mounting Box SC116

The Recess Mounting Box SC116 provides an easy way to mount the detector in the wall and protect the detector from external destruction.

The figure below shows the components of the Recess Mounting Box SC116. For more information, please refer to the *"The Recess Mounting Box SC116 User Guide"*.

Figure 6-10 Recess Mounting Box SC116 Components

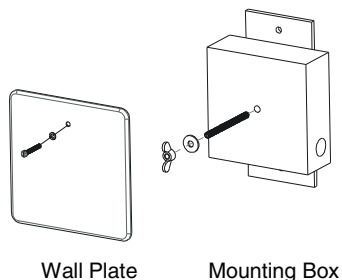

The Floor Mounting Box SC117

The Floor Mounting Box SC117 is designed to provide an easy way to mount the detector recessed in the floor and protect the detector from external destruction.

The figure below shows the components of the Floor Mounting Box SC117. For more information, please refer to the *"The Floor Mounting Box SC117 User Guide"*.

Figure 6-11 Floor Mounting Box SC117 Components

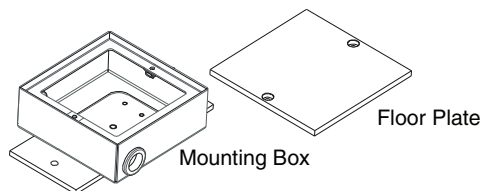

7 Settings

All the settings should be configured on the detector base before the detector is installed permanently. The related function modules are shown as below.

Figure 7-1 Function modules on Detector Base

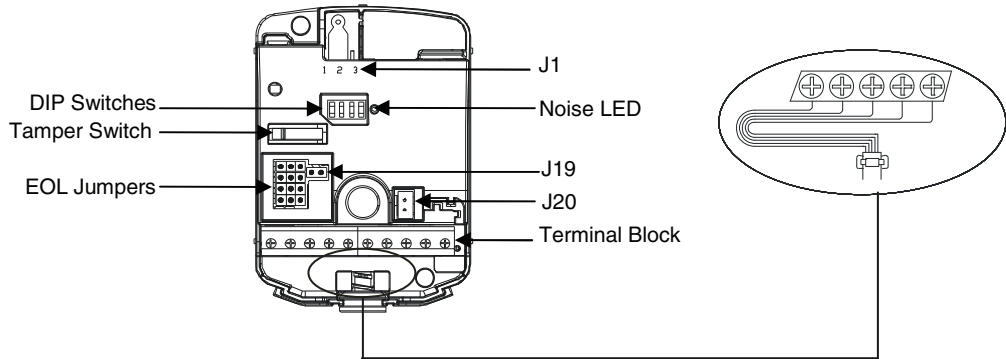

DIP Switch Settings

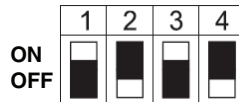

Sensitivity Settings				Application Settings		Noise LED	
	1	2		3		4	
G_{high}	OFF	OFF	High sensitivity setting	OFF	ATMs/ Night deposit safes	OFF	Noise indicator OFF
G_{normal}	ON	OFF	Normal sensitivity setting	ON	Safes / Vaults	ON	Noise indicator ON
G_{low}	OFF	ON	Low sensitivity setting				
G_{noisy}	ON	ON	Noisy environment sensitivity setting				

* Factory default settings are shown in grey.

- Note**
- Any change of DIP switch 3 will cause an alarm.
 - Any change of DIP switch 3 must be followed by a power-off sequence of 5 seconds.
 - The Noise LED will light or flash rapidly if the noise level (external or internal) is too high. Reduce the sensitivity with DIP switch 1 and 2 until the Noise LED turns off.
 - When scratching the surface of the protected object lightly, the Noise LED will turn on as a confirmation of detection.
 - In case of alarm, the Noise LED will flash with 5 Hz, approximately 2.5 seconds.
 - Turning off the Noise LED by DIP switch 4 will reduce current consumption.

EOL Jumper Settings

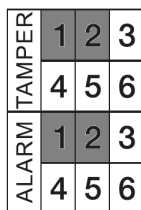

Jumper	Position	EOL Value
TAMPER (RT)	1-2	1K
	2-3	2.2K
	4-5	4.7K
	5-6	5.6K
ALARM (RA)	1-2	1K
	2-3	2.2K
	4-5	4.7K
	5-6	5.6K

* Factory default settings are shown in grey.

Note

- Refer to Control Panel manual for proper EOL selection.
- For each block, only one EOL value can be set.
- Other EOL resistor values can be used by removing all jumpers on the EOL jumper field and wire new resistors directly on the terminal block.

J19/J20 Settings

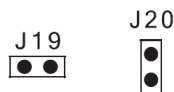

	No Jumper	Jumper
J19	Terminal 8 = Spare Terminal	Terminal 8 = Alarm O/C Output
J20	Connect SC111/SC112 to the loop	Normal Close

* Factory default settings are shown in grey.

J1 Setting



J1 is used for remote testing. For details, please see the *Remote Test* section on page 22.

8 Connecting the Detector

The terminal block of the Detector SC100 should be wired correctly before the detector cover has been secured.

Follow the steps below to wire the pins on the terminal block:

1. Insert and feed the cable through the grommet and cable inlet, see *Figure 7-1 Function modules on Detector Base* for reference.
2. Cut and strip the cable, leaving approximately 10cm (4 in.) of wires after the strain relief.
3. Remove about 6 mm (0.25 in.) of the wire insulation.
4. Wire the terminals according to wiring diagram below.

Figure 8-1 Wiring on the terminal block

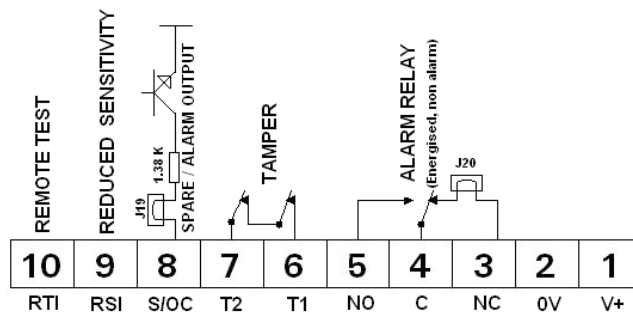

Note The open collector alarm output (terminal 8) will be active low during alarm.

5. Connect the detector to the panel according to the actual application requirements: See *Figure 8-2* for connecting the detector to a zone configured as Dual-End-of-Line and *Figure 8-3* for connecting the detector to a zone configured as Single-End-of-Line.

Figure 8-2 Alarm and tamper configured to one loop

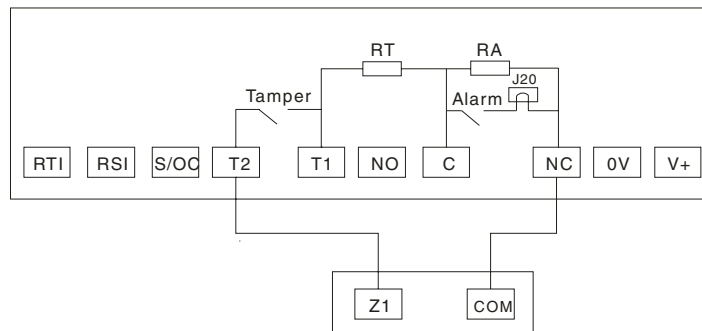
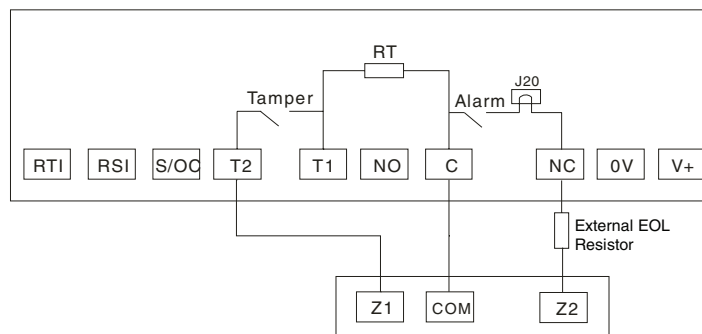

Figure 8-3 Alarm and tamper configured to two loops



Note: When this wiring diagram is used, RT still can be used for the tamper loop, but the jumper on RA needs be removed and the external EOL resistor must be connected to the alarm loop.

9 Test

The Detector SC100 features three important tests in order to provide the highest level of security:

- **Field Test** - Determines the detection range, sensitivity level and mounting location before mounting the detector.
- **Control and Function Test** - Checks the proper mounting and wiring of the detector before mounting it permanently.
- **Remote Test** - Checks the proper function, mounting and wiring of the detector at any time.

Field Test

Before mounting the detector, a field test should be done to determine the detection range, the detector sensitivity, and the proper mounting locations.

The field test should include the following:

- Visual inspection of the construction of the protected object or surface.
- Discovery of any irregularities in the construction.
- Checking the ambient noise level in the premises by activating the Noise LED tool with DIP switch 4.
- Defining the location of each sensor.

For full coverage and complete testing, the items below may be used:

- Note**
- Additional detectors
 - Electric drill and a 6 mm (0.24 in) carbide tipped drill bit
 - The Test Transmitter SC113 and External Test Transmitter SC115
-

Follow the steps below to perform the field test:

1. Locate any irregularity in the construction.

Note The mortar between bricks and blocks should be considered as irregularities.

2. Install a detector at one side of the suspected irregularity.
3. Wire the detector to the power supply and alarm circuit.
4. Set the detector sensitivity to G_{high} .
5. Drill into the wall at a point equal to the detection radius (R) depending on the construction type as described in *Table 2-1 Application Settings* on page 2.
6. Check for an alarm.
7. If an alarm does not occur, assume that the irregularity limits the protection range of the detector. Drill again closer to the sensor until an alarm occurs and identifies the irregularity.
8. Take all irregularities into account when spacing detectors. Additional detectors may be required.

Note The separation between vault door and the frame may require an additional detector on the door to insure detection of the door and wall surfaces.

Control and Function Test

Before leaving the installation, the control and function test should be performed to ensure:

- The proper wiring of the detector, preferably against a wiring diagram.
- The proper mounting of the detector, the Test Transmitter SC113 or External Test Transmitter SC115 (see the “*External Test Transmitter SC115 User Guide*”).

Perform the following tests:

1. Use a screw driver to scratch on the protected surface (safes) and drill in the wall (vaults) at the fringe of the expected coverage area. An alarm from the detector should be activated within 45 seconds.
2. Knock firmly with a hammer around the detector with two-second intervals between blows. After four to seven blows, Detector SC100 in safe and vault mode shall alarm.

-
- Note**
- To protect the surface from damage it is advised to use a small metal plate between the hammer and surface.
 - This test simulates an attack with a hammer and chisel and is only valid for Detector SC100.

3. Give one powerful blow near the detector with a hammer. The detector should give an alarm immediately. This test simulates an attack with explosives.

-
- Note** Check the background noise level in the detector to prevent a false alarm.

4. Activate the Noise LED tool by setting DIP switch 4 to the ON position.
5. Set the sensitivity to G_{high} . Make sure that all possible sources of vibrations in the protected area are present and operating.
6. Check the Noise LED. It will be OFF if the noise level is acceptable. If the Noise LED is flickering or ON, try to find the noise source and remove it.

-
- Note**
- Always try to remove the source of ambient noise before reducing the detection range.
 - Switch OFF the Noise LED tool by setting DIP switch 4 to the OFF position.
 - Set the sensitivity of the detector to an appropriate value. Close the detector cover and check for a closed-loop condition of the tamper-loop. Perform a functional test of both alarm and tamper signals according to the panel specifications.



Remote Test (Alternative)

To reach the highest security level of the Detector SC100, the system provides three different remote test possibilities. For high security installations a daily remote test of the Detector SC100 function and mounting is advised.

- Remote test of the detector electronics, excluding the vibration sensing element.
- Remote test of the detector functionality including the detector vibration sensor element and installation on the protected surface. This test option incorporates the Test transmitter SC113 mounted on the protected surface and under the Detector SC100.
- Remote range test of several Detector SC100s simultaneously. This test option includes remote test of the detector functionality including the detector vibration sensing element and installation on the protected surface, as well as testing of the signal propagation across the solid structure of the protected object between multiple Detector SC100s and the External Test Transmitter SC115.

J1 on the detector base (see *Figure 7-1 Function modules on Detector Base* on page 18) is used for remote testing, and details are shown in the table below.

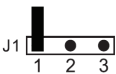
Table 9-1 Remote Test

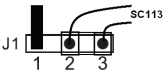
Position	Function	Method	Result
1	 <p>No test</p>	<p>Connect jumper to J1 pin 1 only (or no jumper at all).</p>	
1-2	 <p>Range test with External Test Transmitter SC115 (including mounting check)</p>	<p>See "<i>External Test Transmitter SC115 User Guide</i>".</p>	
2-3	 <p>Electronics test</p>	<p>Connect jumper to J1 pin 1 and 2; Apply an active low 0 volt to terminal 10 on the terminal block to start the test.</p>	<p>A successful remote test will be acknowledged by an alarm from the detector within 1 second.</p>
2-3	<p>Complete test with Test Transmitter SC113 (including mounting check)</p>	<p>Connect Test Transmitter SC113 to J1 (red cable to pin 2 and black cable to pin 3); Apply an active low 0 volt to terminal 10 on the terminal block to start the test.</p>	<p>A successful remote test including mounting check will be acknowledged by an alarm from the detector within 1 second.</p>

* Factory default setting is shown in grey.

10 Technical Specifications

Check the detector mounting and functions regularly (at least once a year).

Note

Connect Terminal 9 to low level (<0.6VDC) to reduce the sensitivity of the Detector SC100 to about 1/8 of original level.

Power Requirements	
Supply Voltage	8 ~ 16 VDC, nominal 12 VDC
Current Consumption (quiescent)	3 mA @ 12 VDC (Noise indicator set to "Off")
Current Consumption (alarm)	2 mA @ 12 VDC (Noise indicator set to "Off")
Voltage Ripple	100Hz, ≤10% of nominal voltage
Step Change	Unom +/- 25%
Slow Change of Supply Voltage	Unom +/- 25%
Warm-up Time	< 5sec
Sensitivity	
Adjustable Sensitivity	4 levels by DIP Switches
Reduced Sensitivity (Maintenance, Service) Input	Active low (terminal 9) < 0.6 VDC
Detection Radius (Thermal Tools) on Concrete (K350)	5 m (16.4 ft)
Detection Radius (Thermal Tools) on Steel	5 m (16.4 ft)
Alarm Outputs	
Solid State Relay SPDT (Change Over)	30 VDC / 100 mA / typical Ri=25 Ω
Transistor Open Collector	Active low during alarm / Ri=1.38 kΩ
Alarm Hold Time	Approx. 2.5 sec
Sabotage Protection	
Pry-off and Cover Switch	30 VDC / 100 mA
Low Supply Voltage Alarm *	< 6.5 VDC
Temperature Alarm *	+85°C ± 5°C (+185°F ± 41°C)
Internal Functional Alarm*	Stainless steel drill shield
* Sabotage and fault functions will cause the alarm relay to drop.	
Inputs	
Remote test of detector mounting and detector function or Remote test of detector electronics only.	Active low < 0.6 VDC, test duration < 1 sec
Reduced Sensitivity (maintenance, service) Input	Active low < 0.6 VDC Duration = as long as active low Sensitivity reduction to 12.5 %
Installation Tool	
A noise and alarm indicator is incorporated to support sensitivity setting.	
Environmental Conditions	
Maximum Humidity	95% RH (non-condensing)
Operation Temperature	-40°C ~ +70°C (-40°F ~ +158°F)
Storage Temperature	-50°C ~ +70°C (-58°F ~ +158°F)
Environmental Class (VdS)	III
Housing Protection Category	IP43 IK04
Housing	
Dimensions (H x W x D)	80 mm x 60 mm x 21 mm (3.15 x 2.36 x 0.83 in.)
Chassis and Cover	Die-cast metal
Color	RAL7035 (light grey)
Weight	0.228kg (8.04 oz)

*Specifications are subject to change without notice.

Honeywell Security & Communications
(EMEA head quarter)
1198, Avenue du Docteur Maurice Donat
BP1219,
06254 Mougins Cedex
France
Tel: +33 (0) 492 942 950
www.honeywell.com

For more information:
www.honeywell.com/security/emea
Fax: +33 (0) 492 942 960

Honeywell Security Group
Avenida de Italia nº 7
Pol Ind C.T.C Coslada
28821 Coslada, Madrid
España
Tel: +34 902 667 800
www.honeywell.com

Más información en:
www.honeywell.com/security/es
Fax: +34 902 932 503
Email : seguridad@honeywell.com

Honeywell Security Group
Ampèrestraat 41
1446 TR Purmerend
Nederland
Tel : +31 (0) 299-410200
www.honeywell.com

Voor meer informatie:
Fax : +31 (0) 299-410201
Email : intrusion.nl31@honeywell.com
www.honeywell.com/security/nl

Honeywell Security Group
2 Corporate Center Drive, Suite 100
P.O. Box 9040,
Melville, NY 11747
USA

For more information:
Tel : 1-800-467-5875
www.honeywell.com

Honeywell Security Group
7 Rue Georges Besse
Immeuble Lavoisier
Parc de Haute Technologie
92160 Antony
France
Tel: +33 (0) 1 40 96 20 50
www.honeywell.com

Pour plus d'informations:
www.honeywell.com/security/fr
Fax: +33 (0) 1 40 96 20 60
Email: contact.intrusion.fr42@honeywell.com

Honeywell Security Group
Novar GmbH
Johannes-Mauthe-Str. 14
72458 Albstadt
Deutschland
Telefon: +49 (0) 7431/ 801-0
www.honeywell.com

Für zusätzliche Informationen:
Fax: +49 (0) 7431/ 801 1220
Email : info.security.de@honeywell.com
www.honeywell.com/security/de

Honeywell Security Group
Honeywell Security Russia
Офис 410, Лужники 24, Москва
119048 Россия
Tel : +7(495)797 - 93 - 71
www.honeywell.com

For more information :
Fax : +7(495)796 - 98 - 93/94

Honeywell Security Group
Newhouse Industrial Estate
Motherwell
Lanarkshire
ML1 5SB
Scotland
Tel:+44 (0) 1698 738200
www.honeywell.com

Find out more:
www.honeywell.com/security/uk
Fax: +44 (0) 1698 738300
email: HSUK64SalesTeam@honeywell.com

Honeywell Security Group
Via della Resistenza 53/59,
20090 Buccinasco
Italia
Tel :+39 0 248 880 51
www.honeywell.com

Per ulteriori informazioni:
Fax : +39 0 248 880 55 33
Email : info.hsce.italia@honeywell.com
www.honeywell.com/security/it

Honeywell Security Group
Honeywell Security Asia Pacific
35/F Tower A, City Center, 100 Zun Yi
Road Shanghai 200051, China
Tel: +86 21.2219.6888
www.honeywell.com

For more information :
Fax : +86 21.6237.0740
www.honeywell.com/security/cn

Honeywell

© 2010 Honeywell International Inc.
<http://www.honeywell.com/security>

© 2010 Honeywell International Inc. All rights reserved. No part of this publication may be reproduced by any means without written permission from Honeywell. The information in this publication is believed to be accurate in all respects. However, Honeywell cannot assume responsibility for any consequences resulting from the use thereof. The information contained herein is subject to change without notice. Revisions or new editions to this publication may be issued to incorporate such changes.